

Macroscopic Design and Determination of Suitability of Linear Viscous Dampers for Seismic Response Reduction of Historical Timber Masonry Building

Saroj Dhakal¹, Prem Nath Maskey²

^{1,2} Department of Civil Engineering, Pulchowk Campus, Institute of Engineering, Tribhuvan University, Nepal

Corresponding Emails: ¹ dhakal.saroj.sd@gmail.com, ² pnmaskey@live.com

Abstract

Historical timber masonry buildings constitute heritage structures of Nepal. Proper seismic rehabilitation and strengthening of these structures are a major concern. In this paper, linear viscous dampers have been proposed and simulated for seismic protection for a historical building – Shiva Parvati Temple. FEM package has been used to model the structure and the seismic response of the structure is obtained by linear time history analysis using modal superposition method. Strategic placement and design of dampers have been presented applying iterative technique on time history analysis. Comparison is made between the results of the analyses of the building with and without the dampers. The significant importance of the damping system in the seismic performance of the building observed is one of the major conclusions of the study. It is also concluded that the structure installed with the damping system along with bracing is substantially effective in reduction of the important structural parameters, such as, top displacement and acceleration, and base shear.

Keywords

Historical Timber Masonry Building – Passive Control – Linear Viscous Dampers – Seismic Response

Nepal, which lies in the subduction zone of Eurasian Plate and Indo-Australian Plate, is categorized in very severe seismic zone [1]. The country has been hit by the severe earthquakes now and then causing much loss of life and property along with damages in historical structures. These structures are in the desperate need of restoration and strengthening [2]. The statement has been validated by the catastrophic damage in the structures by the recent Gorkha earthquake.

Nevertheless, these historical timber masonry buildings are an important part of national heritages. The cultural value of these structures, and the desire to preserve it for the future, demand a high level protection against any possible future destruction under future actions. Among these actions, earthquake is of primary importance [3].

The analysis results for a historical building (compared with the analysis of contemporary structure) depends more on validity of models used (material response models, structural response model, etc.), and less on the choice of proper calculation method [3]. Among the

many techniques for restoration and strengthening of these structures, structural control technique is modern, trending and found to be most effective in contemporary structures. Query of the research is to design and evaluate effectiveness of the structural control system, linear viscous dampers in particular, in timber masonry structures for the seismic rehabilitation and strengthening.

Overview of Passive Structural Control “The basic function of passive energy dissipation devices when incorporated into a structure is to absorb or consume a portion of the input energy, thereby reducing energy dissipation demand on primary structural members and minimizing possible structural damage” [4].



Figure 1: Conventional Base Structure [5]

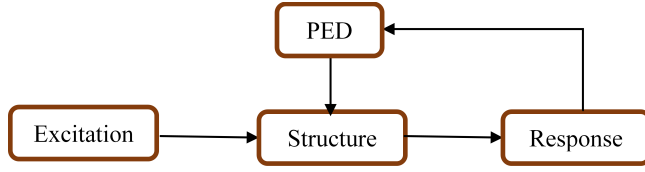

Figure 2: Structure with Passive Energy Dissipation [5]

Advantages of Passive Control System:

1. It is usually relatively inexpensive.
2. It consumes no external energy. Control forces are developed as a function of the response of the structure.
3. It is inherently stable.
4. It works even during a major earthquake.

But the main disadvantage of the system is that it cannot adapt to varying loading conditions hence its effectiveness is limited [6].

Compared to other types of energy dissipaters, fluid viscous damper has these advantages:

1. Activates at low displacements.
2. Can reduce both internal shear forces and deflection in a structure.
3. Self-contained, no auxiliary equipment or power is required.
4. A modern fluid viscous damper is small, compact, and easy to install.
5. For linear damper, modeling of damper is simplified.
6. Properties largely frequency and temperature independent.

Yet the fluid seal leakage questions reliability concern of the fluid viscous dampers [7, 8].

The vibration control devices should address the fact that masonry structures are relatively stiff, so that large energy dissipation must be activated with small displacements. Therefore, fluid viscous dampers (velocity dependent damping devices) are most appropriate for rehabilitation of the historical masonry structures [3].

1. Mathematical Macroscopic Modeling of Linear Viscous Damper

Subjected to uniform base excitation and time varying forces, the equations of motion for the discretized MDOF structural system can be written as equation 1:

$$M\ddot{x} + C\dot{x} + Kx + F_d = -(M + \bar{M})\ddot{x}_g + p \quad (1)$$

where, M , C and K represents the mass, damping, and stiffness matrices, respectively, while F_d represents damping force due to the passive devices. Meanwhile the vector \ddot{x}_g contains rigid body contribution of seismic ground motion to each DOF, and p includes the force due to aerodynamic loading.

By integration the force terms over corresponding relative displacement history, the equation of motion can be represented in the scalar (energy) form as equation 2:

$$E_K + E_D + E_S + E_P = E_I \quad (2)$$

where, E_I is the input energy, E_K is the relative kinetic energy of the mass, E_D is the energy dissipated by inherent structural damping, and E_S is the strain (elastic + hysteretic) energy [4].

The Maxwell fractional derivative model of viscous dashpot model:

$$P(t) + \lambda \frac{dP(t)}{dt} = C_0 \frac{dx(t)}{dt} \quad (3)$$

where, $P(t)$ is instantaneous damping force, $x(t)$ represents the corresponding axial displacement of the damper, λ represents relaxation time, and C_0 represents zero frequency damping coefficient.

For linear, purely viscous dashpot model reduces to simplified force-deformation equation as 4.

$$P(t) = C_0 \frac{dx(t)}{dt} \quad P = F = C_0 |\dot{D}| \quad (4)$$

where, P is the damping force, C_0 is the damping constant, \dot{D} is the relative velocity between the two ends of the damper [4, 9].

The effective damping ratio of the structural system, ξ_{eff} , is defined as 5:

$$\xi_{eff} = \xi_0 + \xi_d = \xi_0 + \frac{\sum_j W_j}{4\pi W_K} \quad (5)$$

where, ξ_0 is the inherent structural damping and ξ_d is the viscous damping ratio attributed to added dampers,

$$W_j = \frac{2\pi^2}{T} \sum_j C_j \cdot u_j^2 \quad (6)$$

W_j (6) is the work done by linear viscous device j in one complete cycle, C_j is the damping coefficient of damper j , u_j is the relative axial displacement of damper j , and W_k is the maximum elastic strain energy dissipated in the structure [9].

Energy concept can thus be utilized for fixing the minimum damping coefficient of each dampers after finding the required damping ratio of the building.

2. Methodology

2.1 Modeling

From the field visit, the structure with sufficient timber masonry interaction was chosen. The structure was macro-modeled using commercial finite element software SAP2000v.17[10] as per measurement at the site. Shorter walls which are faced EW-direction are modeled along global y-direction and perpendicular longer walls along x-direction. Eight noded solid element discretization, with 2 x 2 x 2 numerical integration yet without assigning incompatible bending modes was modeled during the modeling of masonry walls. For the proper forces transfer on the edges of solid, edges of adjacent elements were constrained. The properties of masonry wall were assigned according to test and simulation of brick masonry wall of historical building [11]. Two noded bar elements with corresponding insertion point and hinged connection were used to model timber elements. The elastic properties of timber, Salwood, was adopted from IS 883: 1994[12]. Loading standards are referred to the IS: 875(Part 1):1987 [13] and IS:875 (Part 2): 1987[14]. Links and support elements were modeled most approximate to their behavior in the field. The linear static analysis was done for the building and the basic parameters were found out in order to validate the model.

Table 1: Ground Motion Parameters of the Accelerograms

	Amplitude	Duration	Frequency Content
El Centro	0.3487 g	30s	0.01 @ 1.46 Hz
Lalitpura (bed rock)	0.29 g	20s	0.0077g @ 2.69 Hz
Chamauli	0.459 g	40s	0.013g @ 1.17 Hz

Furthermore, using three accelerograms with different ground motion parameters as shown in table 1, modal linear time history analyses were performed.

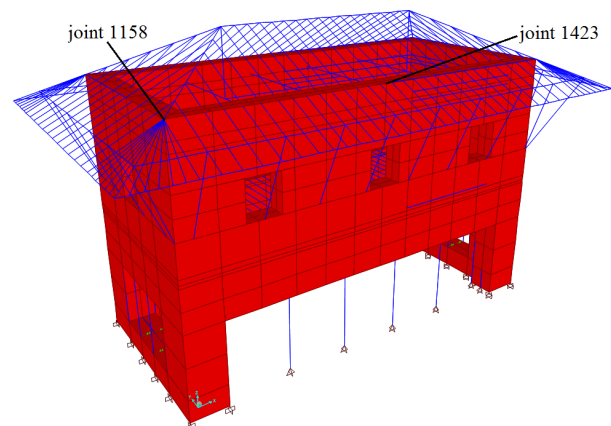

Figure 3: 3D view of the Shiva Parvati Temple modeled in SAP2000v.17

2.2 Damper Design and Installation

The response parameters were calculated for each time history analyses, from three ground motion inputs. The linear dynamic procedures of time history method should be followed for the design rather than response spectrum method when the effective damping in the fundamental mode of rehabilitated building, in any principal direction, exceeds 30% of the critical damping. If three time history analyses are performed, the maximum response of the parameter of interest shall be used for design; yet if seven or more pairs of ground motion records are used for time history analysis, the average response of the parameter may be used for design [9]. The additional bracings, trial position and number of dampers were fixed according to comparative response plot of the original and reformed structure. Dampers placed in the upper levels had little to no effect on the structural response. Significant reduction in seismic response parameters can be achieved by

strategically placing the dampers within the periphery of structure where twisting deformation is significant [6].

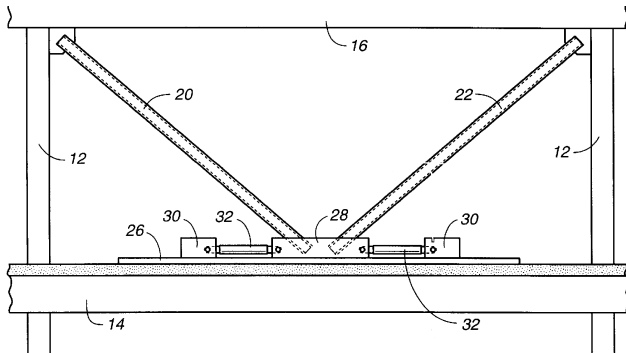

Figure 4: Side view of a building installed with the viscous damper [15]

In the figure 4, 12 = spaced columns; 14 = lower beam; 16 = upper beam; 20, 22 = brace members; 21 = connector plate; 26 = affixed track; 28 = slider; 30 = anchor members; 32 = viscous dampers.

The structure was additionally braced as per patent of Haskell as per shown in figure 4. The damper installation technique was claimed to be characterized by its simplicity and relatively low cost [15].

The damping ratio required for the braced structure was calculated using the response spectral displacement of the maximum displacement point of the structure in order to satisfy the story drift limit stated in IS 1893 (Part I): 2002[1]. Iterative procedure of the linear time history was done referring to the energy approach guidelines of FEMA, 273[9], as shown in the flowchart. When used at 15% to 40% of critical damping range, viscous dampers become economical in terms of overall cost of a structure [8]. Thus the trial number positions, and damping coefficient of the dampers were designed. Yet tested devices showed no measurable stiffness for piston motions with frequency less than about 4 Hz, cutoff frequency, which is a desirable property [8]. In SAP2000v.17[10], the designed damping coefficient was assigned in the axial direction as input parameter of Exponential Maxwell Damper Property. Then the structure with and without damper were comparatively analyzed in terms of response parameters in order to evaluate their performance in the simulated structure.

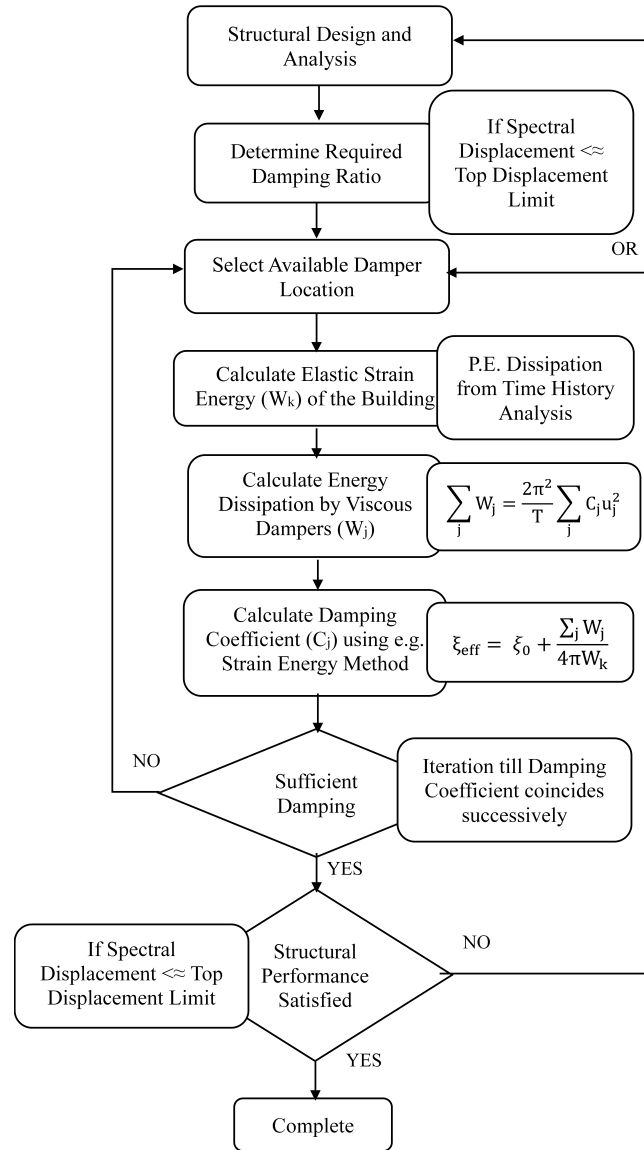

Figure 5: Damper Design Flowchart

3. Results and Discussion

3.1 Validation of the model

The fundamental time period calculated manually from IS 1893 (Part I): 2002 [1] is calculated to be 0.284s approximates the software calculated first modal time period 0.267s. The same structure was modeled assigning the masonry wall as the thick shell element previously and the time period was obtained 0.2549s [16].

The first mode shape of the building, with modal mass participation 75%, incorporates the translation mode

along the Y-direction. The building shows primarily torsional shape in second mode shape, with modal mass participation 54%, which accounts the eccentricity due to large opening on the front part of the building.

Observing the modal participation mass ratios sum in both X and Y-directions, 90% of mass participated within 42 modes unlike framed structures in which more than 90% mass participation was incorporated within first few modes [17].

Base shear calculated manually – 996.65 kN [1]– approximates the software calculated base shear – 1019.15 kN – with discrepancy of 2.2%, which accounts to the approximations and assumptions in loading and structure.

3.2 Energy and Response Parameters

The energy parameters and response parameters both were observed to be significantly higher in case of ground motion along Y-direction.

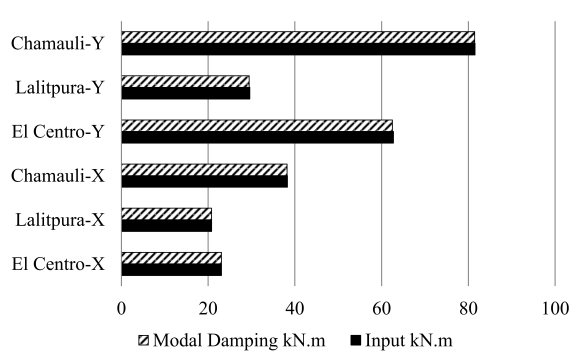

Figure 6: Maximum values of Total Energy Components

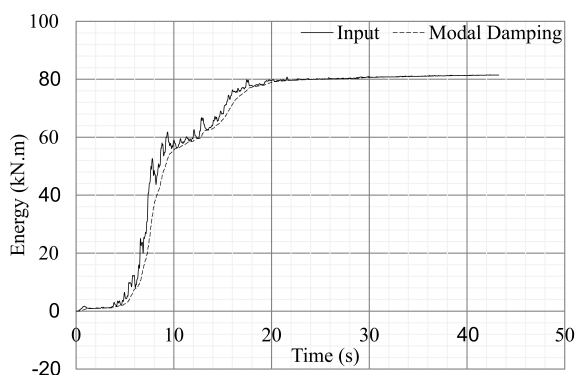

Figure 7: Sample plot of Energy components with time (Chamauli-Y)

From figures 6 and 7, it is clear that almost all of the input energy is dissipated as modal damping energy. Each accelerogram causes more energy components along shorter walls than longer walls. The Chamauli Earthquake has the largest energy components for the building.

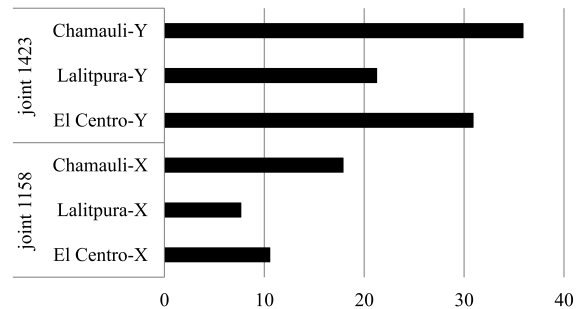

Figure 8: Maximum displacement (in mm)

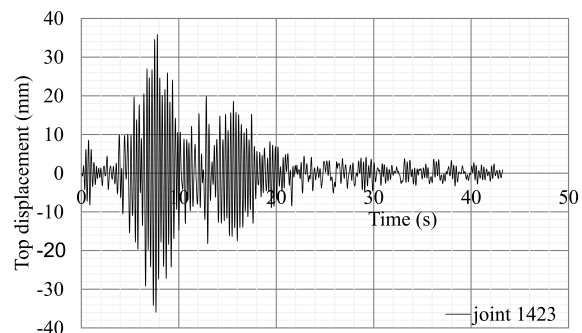

Figure 9: Sample plot of Displacement with time (Chamauli-Y)

Figures 8 and 9 support the result obtained from figure 7 in terms of primary response parameter – top displacement. Hence Among the six cases, damage will be most significant when the building is excited by Chamauli accelerogram along Y-direction of the structure.

3.3 Reformed Structure

The timber bracing (0.3m x 0.3m) system were strategically installed in the model as shown in the figure 10. Thus the modal mass participation of the primary torsional mode shape gets reduced from 54% to 44% and required damping ratio gets reduced from 60% to 35%. The use of timber element as the bracing is due to restriction on use of steel elements in the heritage

Macroscopic Design and Determination of Suitability of Linear Viscous Dampers for Seismic Response Reduction of Historical Timber Masonry Building

structures. 8 dampers, 4 along the x-direction on the front part of the structure and 4 along the y-direction by the side walls, were horizontally installed along with timber bracings strictly following the patent of Haskell [15] as shown in the figure.

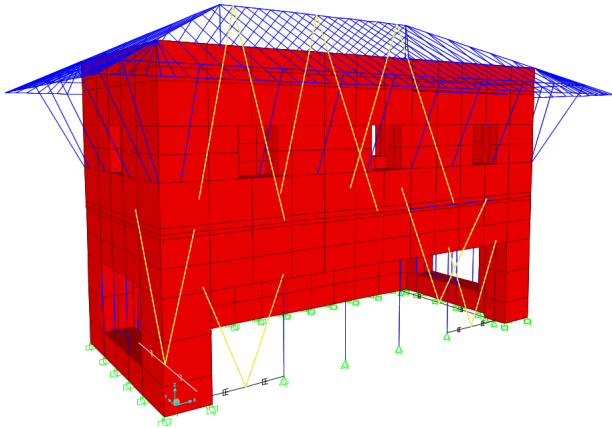

Figure 10: 3D View of simulated structure with bracing and damping system incorporated

3.4 Damper Design

Inherent structural damping for the structure was assigned 3% as recommended for unreinforced masonry structure [17]. In the spectral displacement graph 11 of the building, required viscous damping ratio was fixed in such a way that the equivalent SDOF system doesn't exceed the limit of story drift as per IS 1893(Part I): 2002[1]. Hence the top displacement limit = 0.04 x structural height = 28.36 mm.

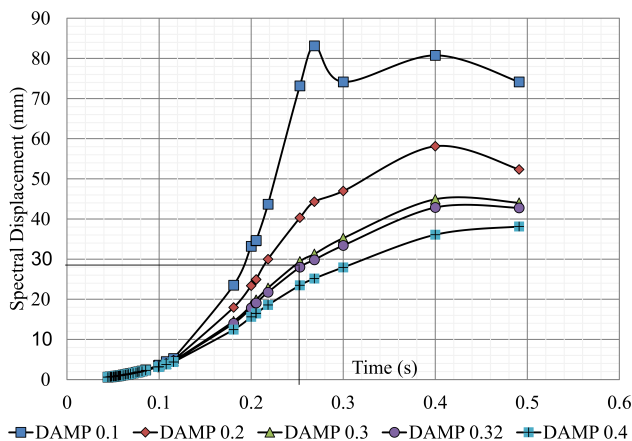

Figure 11: Response Spectral Displacement vs time period Plot of joint 1423 (Chamauli-Y)

From the figure 11, the ordinate with limit of 28.36 mm, and abscissa of fundamental time period 0.253 s meet at the curve of 32% added damping ratio. Thus it is observed that 32% of added damping i.e. effective damping of 35% (32% + 3%) is required for satisfying the drift limit. Then the damping coefficient is calculated, as per energy concept equations 5 and 6, using time history iteration approach. The iterations are presented in table 2.

Table 2: Iteration table for damping coefficient designed for joint 1423, Chamauli-Y

SN	C_j Used (kN.s/m)	Potential Energy (kN.m)	$\Sigma u_j^2 (m^2)$	C_j of each damper (kN.s/m)
1		11.4176	0.003108	189.34
2	190	6.6664	0.002233	153.85
3	150	7.3553	0.002303	164.64
4	165	7.0831	0.002272	160.59
5	160	7.1719	0.002282	161.95

Firstly the damping coefficient of each of the damper is assigned to be 0 in each directions. Then from the time history analysis of the reformed structure, the axial displacements and potential energy are found and thus again the damping coefficient is calculated using equations 5 and 6. The calculated damping coefficient is then assigned in the axial direction of each damper and second iteration is done. Iteration is continued till the successive damping coefficient of the dampers coincides. As the result of 5 iterations as in the table 2, the damping coefficient of the dampers has been designed to be 160 kN.s/m, which is easily available in international market as a conventional damper.

3.5 Comparative Analysis of Response Parameters

After designing the dampers, the damping coefficient is assigned in the axial direction of each damper. Then the time history analysis is performed for both the only braced structure and the braced damped structure. Then the important structural response parameters plot is obtained as in figure 12, 13, and 14.

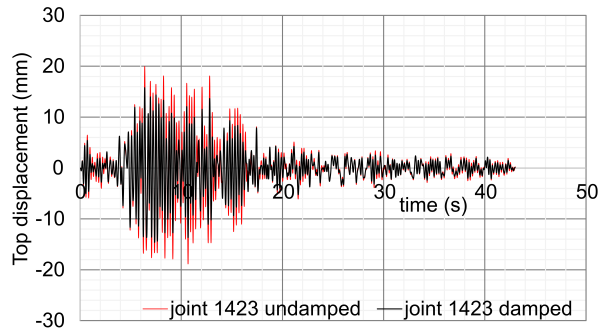

Figure 12: Comparative Plot of Top Displacement between Damped and Undamped Case

The maximum displacement of the joint has been observed to be reduced by 21% due to damping effect of incorporated designed dampers.

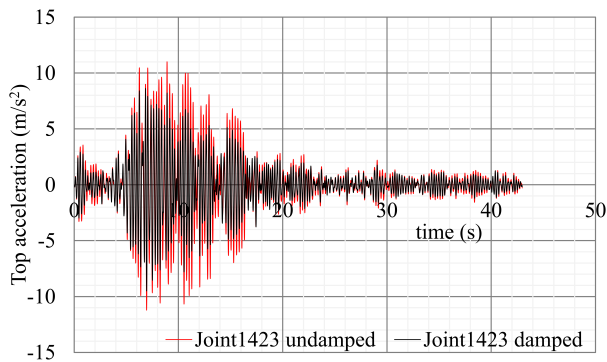

Figure 13: Comparative Plot of Top Acceleration between Damped and Undamped Case

The maximum acceleration of the joint has been observed to be reduced by 15% due to damping effect of incorporated designed dampers.

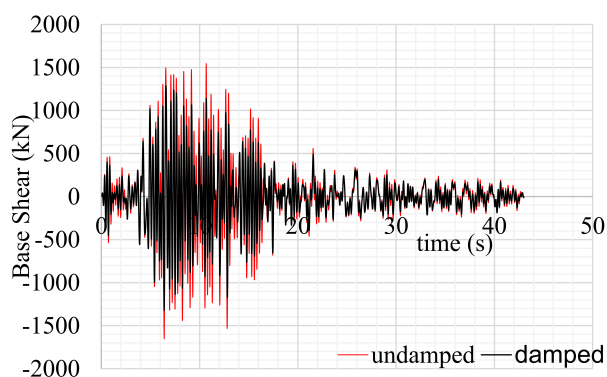

Figure 14: Comparative Plot of Base Shear vs Top Displacement between Undamped and Damped case

The maximum base shear (with time) is observed to be reduced by 20% due to damping effect of incorporated designed dampers.

4. Conclusion

The timber masonry structure has been modeled using FEM package and its seismic response is obtained by linear time history analysis using modal superposition method. Timber bracing is found to be significant for the seismic demand reduction of the building, thus reducing the required damping ratio from 60% to 35%. Furthermore, linear viscous dampers has been designed based on the energy concept of macroscopic modeling using linear time history iteration approach. For the required effective damping ratio of 35% in the structural system, 8 strategically placed dampers each with damping coefficient of 160 kN.s/m have been incorporated in the structure. According to the results of the rehabilitated structure under study, 21% reduction in the maximum top displacement, 15% reduction in the maximum top acceleration, and 20% reduction in the base shear is observed due to the damping of linear viscous dampers. Thus, aforementioned strategical placement of the bracing and dampers can significantly reduce the structural demand of the masonry structures leading to an alternative method of strengthening historical structures against dynamic (earthquake) loads. These results, after further experimental verification, are quite important for the rehabilitation/strengthening procedure of the structure. The major conclusion of the research is that the use of vibration control devices is particularly important, in encountering the lateral (seismic) actions during a structure’s lifetime, and thus effectively protecting the historical structure.

References

- [1] Earthquake Engineering Sectional Committee. Indian standard criteria for earthquake resistant design of structures, part 1- general provisions and buildings (fifth revision), is 1893 (part 1): 2002. Technical report, Bureau of Indian Standards, 2002.
- [2] Sharoo Shrestha. Seismic vulnerability of a historic timber masonry monumental building in nepal. Master’s thesis, Tribhuvan University, Institute of Engineering, Pulchowk Campus, Department of Civil Engineering, 2014.

Macroscopic Design and Determination of Suitability of Linear Viscous Dampers for Seismic Response Reduction of Historical Timber Masonry Building

- [3] CA Syrmakezis. Seismic protection of historical structures and monuments. *Structural control and health monitoring*, 13(6):958–979, 2006.
- [4] Tsu T Soong and Gary F Dargush. *Passive energy dissipation systems in structural engineering*. John Wiley and Sons, 1997.
- [5] Tsu T Soong and Billie F Spencer. Active, semi-active and hybrid control of structures. *Bulletin of the New Zealand National Society for Earthquake Engineering*, 33(3):387–402, 2000.
- [6] Nitendra G Mahajan and DB Raijiwala. Seismic response control of a building installed with passive dampers. *International Journal of Advanced Engineering Technology*, 2(3), 2011.
- [7] MD Symans, FA Charney, AS Whittaker, MC Constantinou, CA Kircher, MW Johnson, and RJ McNamara. Energy dissipation systems for seismic applications: current practice and recent developments. *Journal of structural engineering*, 134(1):3–21, 2008.
- [8] Douglas P Taylor and Michalakis C Constantinou. *Fluid dampers for applications of seismic energy dissipation and seismic isolation*. Taylor Devices, Incorporated, 1998.
- [9] Applied Technology Council (ATC-33 Project). Nehr guidelines for the seismic rehabilitation of buildings, fema 273. Technical report, Federal Emergency Management Agency, 1997.
- [10] *CSi Analysis Reference Manual*, 2015.
- [11] Jhapat B Thapa. Test and simulation of brick masonry wall of historical buildings. Master’s thesis, Tribhuvan University, Institute of Engineering, Pulchowk Campus, Department of Civil Engineering, 2015.
- [12] Building Construction Practices Sectional Committee. Indian standard design of structural timber in building-code of practice, is 883: 1994. Technical report, Bureau of Indian Standards, 1994 (Reaffirmed 2005).
- [13] Structural Safety Sectional Committee. Code of practice for design loads (other than earthquake) for buildings and structures part 1: Dead loads- unit weights of building materials and stored materials, is 875 (part 1)-1987. Technical report, Bureau of Indian Standards, 1987 (Reaffirmed 1997).
- [14] Structural Safety Sectional Committee. Code of practice for design loads (other than earthquake) for buildings and structures part 2: Imposed loads, is 875 (part 2)-1987. Technical report, Bureau of Indian Standards, 1987 (Reaffirmed 1997).
- [15] Gregg O Haskell. Building damper apparatus, December 8 1998. US Patent 5,845,438.
- [16] Bibek Sigdel. Seismic vulnerability assessment of historic structures (a review of existing methodology). Master’s thesis, Tribhuvan University, Institute of Engineering, Pulchowk Campus, Department of Civil Engineering, 2015.
- [17] Anil K Chopra. *Dynamics of structures: theory and applications to earthquake engineering*. Pearson Education, Inc. and Dorling Kindersley Publishing Inc., 2007.