

# Techno-economic Analysis of Solar PV/Diesel Hybrid Energy System for Electrification of Television substation- “A Case Study of Nepal Television Substation at Ilam”

Sher Mohammad Husain, Dinesh Kumar Sharma

*Department of Mechanical Engineering, Energy System Planning and Management,  
Central Campus, Pulchowk, Institute of Engineering, Tribhuvan University, Nepal*

Corresponding Email: sher105@yahoo.com

---

**Abstract:** This paper presents the most feasible configuration of Solar PV system with diesel generator as back up for the electrification of Nepal Television (NTV) substation situated in Ilam (26°58'N, 87°58'E) district in the Eastern development region of Nepal having transmitter power of 5 kW. In this study the attempt has been made to model a hybrid electricity generation system for a television substation. This system incorporates a combination of solar PV, battery and diesel generator. HOMER, software for optimization of renewable based hybrid systems has been used to find out the technically feasible renewable energy efficient system for the site. Meteorological data of solar insolation of the site have been taken from online data from NASA. The cost of components is taken from the online site of manufacturing and equipment suppliers. Sensitivity analysis is also done to see the impact of diesel fuel price and solar insolation. This system can reduce CO<sub>2</sub> emission by about more than 44 tons per year compared to diesel generator only system. The proposed system can supply the daily energy demand of 121 kWh per day with 9.8 kW peak for 24 hours. Technical and economic analysis of the optimum system has been done to compare the economic viability of solar photovoltaic (PV)/ gen/battery hybrid power system with that of a standalone diesel generator only system.

**Keywords:** HOMER; Photovoltaic; Diesel generator; Hybrid energy system

---

## 1. Introduction

Ilam District is a hill district of Mechi zone in Nepal's eastern development region. The district covers 1,703 km<sup>2</sup> (658 sq. mi). The 2011 census counted 290,254 populations. Ilam is the headquarters, about 600 km (379 mi) from Kathmandu. The Latitude is 26°58'N and Longitude is 87°58'E (District profile of Ilam, 2010)[1].

Now, moving on to the project area where Nepal Television have provided a Television Repeater station having 5 kW VHF Transmitter at Tinchuley Ilam district for the terrestrial broadcasting. (NTV, 2013) Current Status of the site is facing the problem of increasing Load shedding. So that the people of that area are unable to receive the transmission signal to their television receiver. For the Peak load NTV has installed a 50 kVA diesel generator as a backup power source. But due to the scarcity and unavailability of diesel and also increasing price of diesel fuel per year as well as load shedding there is still problem of meeting the demand. Also due to the increasing fuel consumption it has not only increased the operating cost but also contributing large amount of GHGs emission to the environment, Also due to repair and maintenance and frequent start up and shutdown procedures decrease their lifetime as well. That's why there is necessity of techno economic system design to solve the above problem.

The solution for the above problem is the use of renewable energy such as solar photovoltaic as an energy source. However, one of the main problems of standalone system such as solar is the fluctuation of energy supply, resulting in intermittent delivery of power and causing problems of supply continuity is required. This can be avoided by the use of standalone hybrid systems. A hybrid system can be defined as a combination of different but complementary energy generation system based on renewable energy or mixed renewable energy source with a backup Liquefied Petroleum Gas (LPG)/ Diesel/Gasoline gen set.

The hybrid system used in this study is Solar PV/ Diesel Hybrid System. The analysis has been done by using HOMER software [2]. Economic comparisons has been done with the other system and optimal hybrid Solar PV/ Diesel gen/ Battery case.

The study on technical and economic assessment of solar PV/ diesel Hybrid power system for rural school electrification is has been carried out by Zelalem Girma (2013) and found that PV/Diesel/battery hybrid power system is feasible in terms of economics as well as technically. It has also less greenhouse gas emission and therefore reduces negative externality of diesel generator. Also cash flow summary of hybrid and stand alone diesel generator system, the hybrid system has a high initial capital cost and low operating and fuel cost. Whereas the stand alone diesel system has a low capital cost and high operating and fuel cost [3].

Different types of renewable energy sources are nowadays used to supply different applications in rural and urban areas (Bhandari, 2011)[4]. Increased reliability and energy security issues are of the most benefits that can be achieved by using hybrid renewable systems (Kamalapur, 2011; Daud, 2012) [5, 6]. Hybrid systems that depend on photovoltaic (PV) are considered the most popular among other types of renewable systems. The main advantages of this technology are their low maintenance costs and low pollutant emissions (Twaha, 2012) [7].

Tamer Khatiba, A. Mohameda, K. Sopianb, M. Mahmoud (2011) Optimal sizing of building integrated hybrid PV/diesel generator system for zero load rejection for Malaysia. The optimization presented in this paper aims to calculate the optimum capacities of a PV array and diesel generator, which investigate the minimum system cost. The results of the optimization show that a PV/diesel generator choice is more feasible compared to a standalone PV system or diesel generator system because it reduces the system cost by 35% [8].

M.S. Ismail, M. Moghavvemi, T.M.I. Mahila (2011) have presented An economic feasibility study and a complete design of a hybrid system consisting of photovoltaic panels, a diesel generator as a backup power source and a battery system supplying a small community in Palestine. Three scenarios have been analyzed in the paper. The most economic scenario is the one that includes in addition to the PV panels, the battery system and the diesel generator. The COE for this scenario is found to be 0.326 \$/kWh and happens at 100% PV contribution and 0.7 AD. Other scenarios dependent on standalone PV and diesel only give results of COE greater than this value. For the diesel only scenario, both the COE and amount of produced CO<sub>2</sub> are greater. The amount of produced CO<sub>2</sub> is about 7 times greater compared to the hybrid one [9].

Benjamin O. et al. Analyzed life cost of diesel-photovoltaic hybrid power system for off grid residential building in Enugu Nigeria. The main aim of analysis is to compare the Life Cycle Cost (LCC) hybrid system with that of single standalone photovoltaic system and stand alone diesel generator options. The life cycle cost analysis of the systems has been done by comparing the Net Present Value (NPV) and the Internal Rate of Return (IRR) of the three options. The result shows that the diesel/photovoltaic hybrid system has small LCC when compared to that of standalone single source Photovoltaic and diesel generator options. Moreover, apart from the economic gain, the hybrid system is also environmentally friendly because of the reduced emission of greenhouse gasses and other pollutants associated with diesel[10].

Lal et al.( 2011) had used the HOMER software for the optimization of PV/wind/micro-hydro/diesel hybrid power system. The simulation through homer software results shows that the cost of energy in the proposed scheme is comparably higher than the conventional energy resources. But this scheme is highly preferable for rural and remote areas where installation and operation and maintenance and extended grid systems are very difficult and costly.

Martin Braun, Zelalem Girma (2013) techno economic assessment and optimization study of hybrid Power system using homer software for electrification of rural district in Ethiopia, The finding indicate that photovoltaic/wind/diesel generator hybrid system was feasible systems based on some important parameters such as high renewable penetration, less annual diesel consumption, less carbon dioxide emission, less unmet load, less capacity shortage and cost of energy.

Eyad S.Hrayshat [11] has performed a detailed techno economic analysis of hybrid PV-diesel -Battery system by using HOMER simulation and Optimization software to meet the load demand of off grid house located in the remote Jordanian settlement. The hybrid system is economically feasible for diesel fuel price above 0.15\$/liter. The optimum system reduced the operating hour of diesel generator by 19.3%, diesel consumption by 18.5 % and 18% reduction of emission of green house gases in comparison with the diesel only situation. Two control strategies have been used in simulation. The first is load following energy dispatch strategy on which whenever the diesel generator starts it produce only enough power to cover the load and lower priority loads such as charging battery bank left to renewable power source. The second dispatch strategy used is cyclic charging on which whenever the generator operates it operate at full output power and the excess electricity charges the battery bank if it is not full or go to low priority load such as water pumping. Otherwise, the excess electricity dumped in the dump load. In this study the diesel generator brought on line at the time when PV fails to satisfy the load and when the battery storage is depleted.

Chaurey and TC Kandpal [12] presented a techno economic comparison of rural electrification based on solar home system (SHS) and PV micro grid in India. Techno economic comparison of the two options has been done to facilitate a choice between the two systems. A comparison was based on annualized life cycle cost (ALCC) for the same type of load and load pattern for varying number of household and varying length and cost of the distribution network. The study analyzed the viability of the two options from the perspective of the user, the energy Service Company

and the society. For purposes of analysis they have selected two types of load with daily energy consumption of 72Wh/ day and 144Wh/day. The result of the study shows that a micro grid is financially more attractive option for the user, the energy Service Company and the society, if the village has a large number of households, densely populated and lies in a geographically flat terrain. Whereas, the SHS is a better option for rough terrain and if the community is small and sparsely populated.

Shaahid and El Amin [13] performed techno-economic evaluation of PV/diesel/battery hybrid power system for rural electrification in Saudi Arabia. They analyzed solar radiation of Rafa to assess techno-economic feasibility of PV/diesel/battery hybrid system for a typical remote village of Rawdhat Bin habbas, which has electrical energy demand of 15,943MWh. The Simulation has been done by using HOMER software and the result indicates that PV/diesel/battery hybrid system is technically and economically feasible with levelized cost of energy of 0.170 \$/kWh. The Study also indicates that the initial cost of Hybrid system is higher than stand alone diesel generator system. The PV cost covers 78% of the total initial cost of the system. The increase in PV penetration decreases the operating hour of diesel generator which further augmented by including battery storage in the system. The running cost of diesel generator only system is much higher than that of hybrid system due to continuous cost of diesel fuel.

K. M. Ironi Udumbara ranaweera [14] performed techno-economic optimum sizing of hybrid renewable energy system for rural electrification in Sri Lanka. A PV/wind/battery bank/diesel generator hybrid system has been found as the optimum system with capacities of 30 kW, 40 kW, 222 kWh and 25 kW respectively. The estimated value of the levelized cost of energy obtained from the lifetime cost analysis is 0.34 \$/kWh. It has been found that the cost can be further lowered approximately to 0.2 \$/kWh with the reduction of O & M cost and with the help of the government subsidies. The energy cost of 0.2 \$/kWh is acceptable and affordable for rural consumers, even though it is not as low as the price of the electricity from the national grid in Sri Lanka.

Rui Huang, Steven H. Low, Ufuk Topcu, K. Mani Chandu, Christopher R. Clarke have done a case study of the Catalina Island in California for which a system with photovoltaic (PV) arrays, wind turbines, and battery storage is designed based on empirical weather and load data. The analysis has been done based on HOMER analysis and simulation shows that PV/Wind Turbine/ Storage are the optimal system design.

In this paper PV/diesel hybrid system is used to electrify the Nepal television repeater station in Ilam. Optimization and economic analysis have been done by using HOMER optimization software. The proposed system relies on renewable energy to generate 93% of total energy. The large share of renewable makes the system independent and lowers the price over the long term, and the diesel generator is used as a backup to assist during periods of high loads or low renewable power availability and covers only 7% of total energy need.

## 2. Objective

---

The main objective of this paper is to analyze techno economic viability the Solar PV/ Diesel generator hybrid technology for electrification of the Nepal television repeater station in Ilam district. The analysis has been made by using HOMER software. Comparisons have been done with the diesel system and optimum hybrid PV/diesel/gen/battery system.

## 3. Methodology

---

In order to design PV/Diesel hybrid power system by using HOMER optimization software, one has to provide some inputs such as hourly load profile, monthly solar radiation value for a PV system, the initial cost of each component (renewable energy generators, diesel generators, battery and converter) cost of diesel fuel, annual real interest rate project lifetime, etc. The solar radiation data of Ilam were taken from online data of NASA meteorological department [15]. The capital cost of each equipment taken from solar buzz site [16]. The load profile of the station determined by using the wattage and hour of use of equipment considered. To get hourly load profile of the station Excel spreadsheet program is used.

HOMER simulates the operation of a system by making the energy balance calculation every hour for each of the 8760 hours in a year. It displays a list of configurations sorted based on the Total Net Present Cost (TNPC). The total net present cost represents the life cycle cost of the system. The calculation assesses all costs occurring within the project lifetime, including initial set-up costs, component replacement cost, maintenance and fuel cost. However, the system configuration based TNPC is varied depending on the sensitivity variables that have been chosen by the author. Therefore, the software repeats the optimization process for every selection of sensitivity variables. In this paper monthly solar radiation and diesel fuel price has been used as sensitivity variables. The final

optimal solution of a hybrid renewable energy system is referring to the lowest TNPC.

#### 4. Hybrid Renewable energy System

In this study solar energy has been used with a diesel generator. The Hybrid System components consist of an electric Load, Renewable energy Source (Solar) and other system components such as PV, battery, and converter. Figure 1 shows below the complete hybrid renewable energy system.

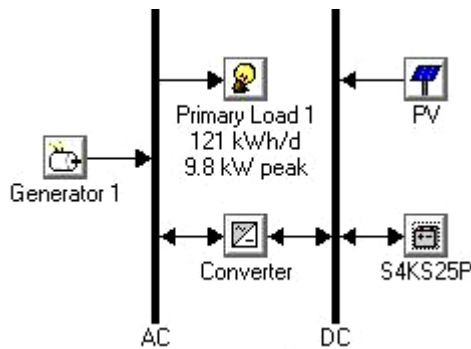

Figure1: Complete hybrid renewable energy system

In this study, The Ilam transmission station has been considered. The basic Load parameters are 5 kW VHF transmitter, 3 Fluorescent tube light (36 W each), 2 Television (TV, 80 W each). Measured hourly load profile is not available. So the load data were synthesized by specifying typical daily profiles and then adding some randomness of daily 10% and 15% noise. These have scaled up to the primary Load 122 kWh/day and Peak load to 9.8kW.

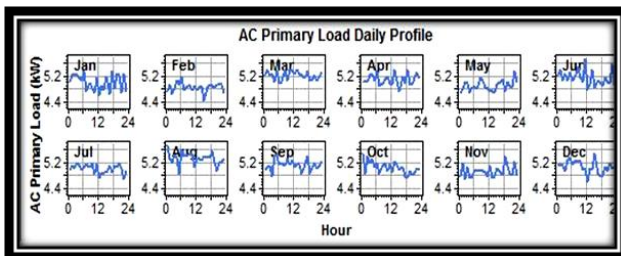

Figure 2: AC primary load daily profile

### 5. System Description

#### 5.1 Load Profile of the Station

The selected station for the study includes the major load components have explained above and based on this data the hourly and monthly load profile is shown in the figure 3 & 4 below.

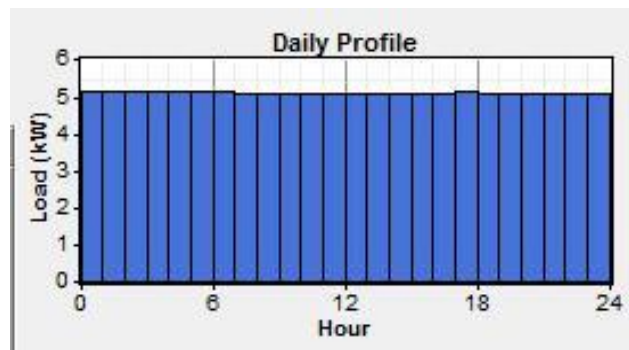

Figure 3: Daily Load Profile

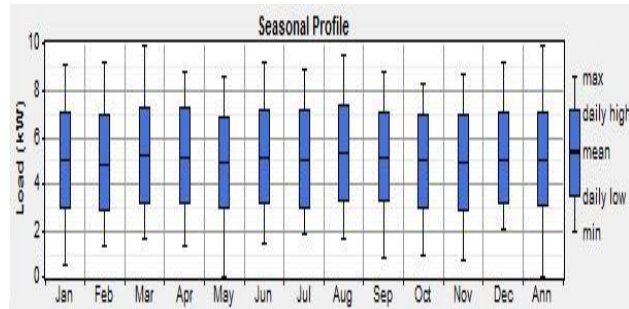

Figure 4: Monthly Load Profile

#### 5.2 Solar Resources

Main Electrical generator of the proposed system is photovoltaic panel which converts solar irradiation directly into electricity. Since the solar radiation varies daily, hourly and seasonally the electricity produced by the PV array vary accordingly. Since the selected site has good solar radiation throughout the year and battery storage and diesel generator are incorporated in the system to handle this variability. However, in order to capture the maximum amount of energy from the solar photovoltaic panel the following factors should be considered during and after the design of the system.

- Total size of solar PV array
- Type of module / array used
- The orientation of the module/array
- The angle from Horizontal
- Anything that shades the array
- The local minimum and maximum ambient temperature and etc.

The proposed design accounts for the decrease in PV efficiency panels with the ambient temperature. As hourly data is not available therefore monthly averaged global radiation data has been taken from NASA (National Aeronautics and Space Administration). HOMER introduces clearance index from the latitude and longitude information of the selected site. Homer creates the synthesized 8760 hourly values for a year using a Graham Algorithm. Fig.5 illustrates the solar

radiation is high between February to April. The average annual clearance index is 0.569 and the average daily radiation is to 5.1 kWh/m<sup>2</sup>/day.

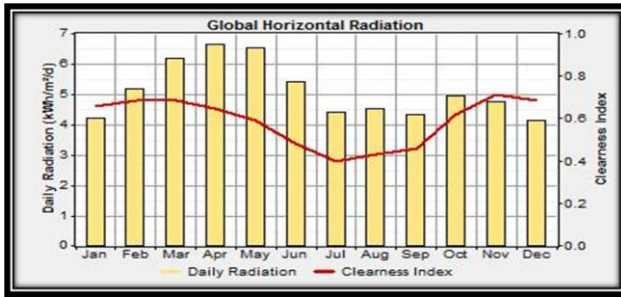

Figure 5: Solar radiation data through the year

Table 1: Monthly Averaged Air Temperature at 10 m above the surface of the earth (°C)

Months	Surface Temperature (°C)
Jan	14
Feb	16
Mar	20
Apr	22
May	22
Jun	24
Jul	24
Aug	24
Sep	23
Oct	20
Nov	17
Dec	15
<b>Annual Average</b>	<b>20</b>

## 6. Data in Homer Software for different Component

The major components of hybrid energy system are PV panels, diesel generator, batteries and converters. For economic analysis, the number of units to be used, capital costs, replacement and O&M costs and operating hours to be defined in HOMER in order to simulate the system.

### 6.1 Solar Photovoltaic

The cost of PV module including installation has been considered as \$1.03. Life time of the modules has been taken as 25 years. 5 kW to 70 kW modules are considered. The parameters considered for the simulation solar PV are furnished in the table 2.

Table 2: Solar PV array-technical parameters and cost assumption

Parameter	Value
Capital cost	\$1.03/W
Replacement cost	\$1.03/W
Operation and Maintenance cost	0
Lifetime	25 Years
Derating factor	90%
Tracking System	No Tracking System

### 6.2 Diesel Generators

The Fuel used in homer is modeled by a linear curve characterized by slope and intercept at no load. For a capacity range of 20 kW to 50 kW, the slope and the intercept are 0.2 L/h/kW and 0.12 L/h/kW respectively. A diesel generator with its technical and economic parameters furnished in the table 3.

Table 3: Diesel generator-technical parameters and cost assumption

Parameter	Value
Size	1 kW
Capital cost	\$600
Replacement cost	\$500
Operation and Maintenance cost	\$0.075
Lifetime	15000 hours
Minimum load ratio	10%
Fuel curve intercept	0.2 L/hr/kW
Fuel curve slope	0.12 L/hr/kW
Fuel price	\$1.1/Liter

### 6.3 Battery

The Surrette 4KS25P storage batteries are utilized in the hybrid system. The specifications like life time, efficiency, rectifier capacity and efficiency, capital and replacement cost are shown in the table 4.

Table 4: Battery-technical parameters and cost assumption

Parameters	Value
Technology	Surrette 4KS25P
Capacity	7.6 kWh
Nominal capacity	1900 Ah
Voltage	4V
Minimum state of charge	40%
Capital cost	\$1300
Replacement cost	\$1200
O& M cost	100\$/year
Efficiency	80%
Lifetime	12 year

## 6.4 Power Converter

The power converter is used to maintain the flow of energy between AC and DC components. The technical and economic parameter for the considered converter is furnished in table 5.

**Table 5: Power Converter-technical parameters and cost assumption**

Parameter	Value
Capital cost	\$700/kW
Replacement cost	\$700/kW
O&M cost	70\$/year
Efficiency	90%
Lifetime	10 year

## 6.5 Hybrid System Control and Constraints

The project has been considered to be 25 years and the annual interest has been taken as 6.5%. The capacity shortage penalty is not considered. The operating reserve and system constraints are furnished in the table 6 and 7.

**Table 6: Spinning reserve inputs**

Parameter	Value
Percent of annual peak load	8
Percent of hourly load	10
Percent of hourly solar output	25

**Table 7: Constraints used in HOMER**

Parameter	Value
Maximum unreserved energy	0%
Maximum renewable fraction	0 to 100%
Maximum battery life	N/A
Maximum annual capacity shortage	0%

## 7. Optimization of Result

To evaluate the performances of different hybrid systems in this study, optimal system performance analysis have been carried out using HOMER simulation tools. In this software the optimized results are presented categorically for a particular set of sensitivity parameters like solar radiation, diesel price, maximum capacity shortage and renewable fraction. HOMER performs thousands of hourly simulations over and over in order to design the optimal hybrid system. Simulations have been conducted considering different values for solar radiation, minimum renewable fraction, and diesel price providing more flexibility in the experiment. The optimization result

for solar radiation parameters 5.1 kWh/m<sup>2</sup>/day and diesel price 1.1\$/liter are illustrated in the table 7. It is seen that a PV, Diesel generator and battery hybrid system is economically more feasible with a minimum (Cost of energy) COE of 0.495\$/kWh and a minimum Net present cost (NPC) of \$266,892. The hybrid system comprised of 45 kW PV array, a diesel generator with a rated power of 10 kW and 36 storage batteries in addition to 11 kW converters is found to be most feasible system. Table11 shows the details related to energy generated by PV and diesel generator, excess electricity, unmet load capacity shortage and renewable fraction for the most economically feasible system applicable for the selected location.

**Table 8: HOMER optimization of results**

Parameters	Model	
	PV /Gen/Battery	Gen/ Battery
PV (kW)	45	
Generator (kW)	10	10
Battery( S4KS52P)	36	16
Converter (kW)	11	6
Initial capital (\$)	140,681	31,000
Operating cost (\$/year)	10,347	28,374
Total NPC	266,892	377,106
COE(\$/kWh)	0.495	0.700
Renewable fraction	0.93	0.00
Diesel (L)	2,555	17,336
Generator (hours)	1061	5936
Battery life	12	12

## 8. Sensitivity Analysis

Two sensitivity variables have been chosen into accounts the variation of these variables in the future. The chosen variables are amount of solar radiation of the site and the price of diesel fuel. It is assumed that these two variables highly affect the cost of the system. This analysis help to analyze which system is optimal for the different values of these two parameters. The output of sensitivity analysis is shown as graph as shown in fig.6 As seen from the fig.6, PV/Gen/battery is optimal solution until the solar radiation as well as diesel price will reach 2.17 kWh/m<sup>2</sup>/day and 0.607\$/L respectively. For this value of solar radiation and diesel price Gen/battery system will be optimal. The current diesel fuel price for the site is around 1.1\$/liter [17].

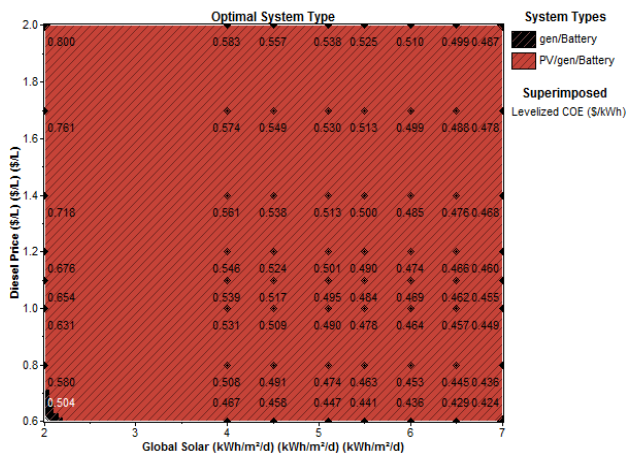

**Figure 6: Graphical Result of sensitivity analysis between Diesel fuel price and solar radiation value for optimal Hybrid system**

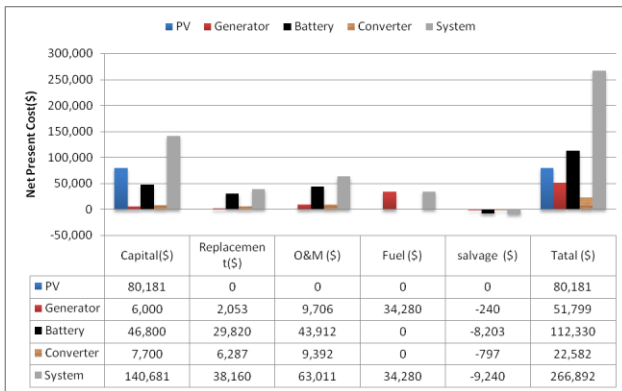

**Figure 7: Cost Summary of the Hybrid system**

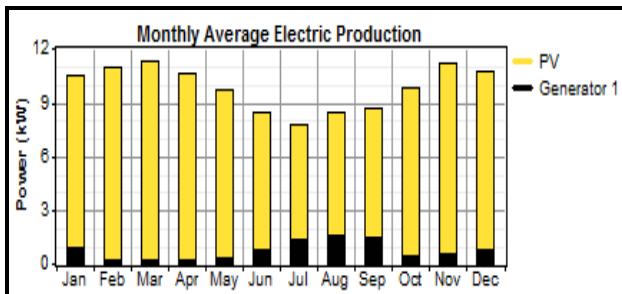

**Figure 8: Monthly average electricity production from the considered components**

## 9. Diesel Generator Power System

The Current power system during no grid supply is only diesel generator. The site has a diesel generator of 50 kVA. This operates around 15 hours per day consuming 10 liter diesel per hour. According to this scenario the there is big problem of frequent start up and shutdown. This have increased the maintenance cost and also the operating cost is large because of the price of diesel fuel is not constant over time. So it is

found that this type of power system is not much reliable in its operation. For the long run it is not feasible. The greenhouse emission from this system is also large. So that from the various perspectives like socio, economic and technically this is not viable. And there is need of any other modes of power system like renewable energy power system.

The figure 9 below shows the base case system of the site during no grid supply.

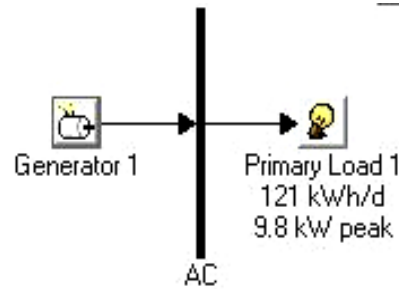

**Figure 9: Diesel Generator System**

The figure above shows is the base case of the site. This is used to compare with the hybrid system. The simulation result at sensitivity cases for the site having Load Scaled Average: 121kWh/d and Diesel Price: \$1.1/Liter suggest the system architecture of 10kW DG. This system produced a total NPC \$285231, LCOE \$0.707/kWh and operating cost \$22892/year with 14495 liters of diesel consumption per year (Table 9).

**Table 9: Optimization Result for Diesel System**

System	Diesel Generator system
DG Size	10kW
Initial capital	\$6000
Operating Cost	\$22,892/Year
Total NPC	\$285,231
LCOE	\$0.707/kWh
Diesel consumption	14,495 Liter/Year
DG Operation hours	6,570

**Table 10: Comparison of greenhouse gas emission**

Pollutants	PV/Gen/battery Hybrid system Emission (Kg/yr )	Diesel Generator only system Emission (Kg/yr)
Carbon dioxide	6,728	50,943
Carbon monoxide	16.6	126
Unburned hydrocarbons	1.84	13.9
Particulate matter	1.25	9.48
Sulfur dioxide	13.5	102
Nitrogen oxides	148	1,122

## 10. Analysis of the Optimal Hybrid System

The techno economically optimum configuration of the hybrid system which can supply the electricity to a selected transmission station having an approximate load profile given in Figure 3, has been found using the HOMER optimization and sensitivity analysis. The HOMER optimization results given in table 8, this configuration is ranked in the 1<sup>st</sup> place. This have higher renewable fraction than other also the net present cost of this configuration is lower than other. That's why it is ranked in the first place. According to the simulation results, this project requires an initial capital of approximately \$ 140,681 and the total NPC of the project is \$ 266,892. This system can supply the electricity for a levelized cost of 0.495 \$/kWh.

Figure 7 gives a comprehensive summary of the net present values of different costs involved in the project throughout its lifetime of 25 years. From discounted cash flow graph for the project lifetime it is found that, after 12 years battery replacement occurs. Also the diesel generator replacement occurs after 14.1 year of its operation. Because the hours of operation of the generator during a year is about 1061 and therefore the total operating hour during the project lifetime is 26525 which is greater than the lifetime operating hours of generator (15000 hrs.)

### 10.1 Performance of the Hybrid System

Monthly average electric power production from each of the system components in the hybrid system is shown in Figure 8; here we can see that the largest percentage of the power is generated by the Solar PV. Especially the generated power from the PV is considerably higher during the months from October to May. On the other hand the average power generated from the PV is relatively small during the period of June to September. Therefore, the diesel generator has to produce much more energy during June to September than the other month. As can be seen in the figure, energy generation from the renewable systems is considerably high during October to May. But still there is a contribution from the diesel generator. That implies that the diesel generator is still required to supply the peak demand during this period.

Table 11 summarizes the annual energy generation figures from the different components and other relevant performance indicators of the hybrid system. The PV generates the highest percentage of 93 % of the total annual energy generation while the diesel generator generates only 7 % of the total. Therefore the renewable fraction of the system is 0.93. As stated in the table, 36.2 % of the total annual energy generation

is excess energy. Which can be used for the other puposes. There is no capacity shortage of this system.

**Table 11: Electrical performance of the hybrid system**

PV array energy production	79.964 kWh/yr	93%
Diesel Generator energy production	6408kWh/yr	7%
AC primary load	44,165 kWh/yr	100%
Excess Electricity	31304 kWh/yr	36.20%
Capacity shortage	0.00 kWh/yr	0.00%
Renewable fraction	0.926	
Hours of operation of diesel generator	1061 hour/year	

### 10.2 Effect of Changes in Annual Average Solar Radiation

The selected hybrid system configuration is optimized for the annual average solar radiation of 5.1 kWh/m<sup>2</sup>/day. According to Figure 10 we can see that the Levelized cost of energy (LCOE) decrease as the annual average solar radiation increases and also we can see from the figure 11 due to increase in annual average solar radiation the renewable fraction also increases.

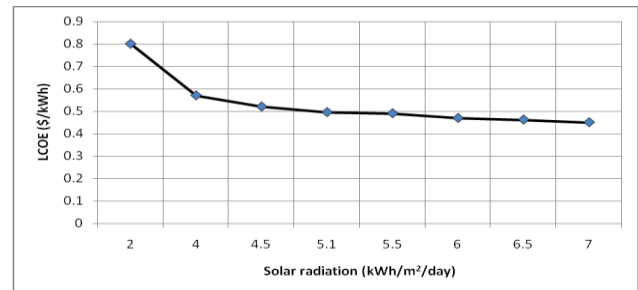

**Figure 10: LCOE at different annual average solar radiations**

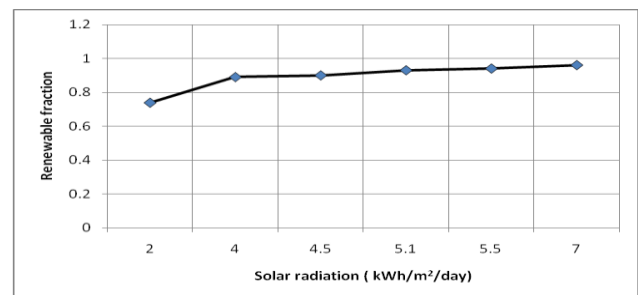

**Figure 11: Renewable fraction at different annual average solar radiation**

## 11. Conclusion

The study simulates a PV/diesel/battery hybrid energy system in Ilam transmission station of Nepal



Television. The optimized hybrid energy system was developed considering manufacturing cost and efficiency. The result shows that the COE of the optimized system is 0.495\$/kWh. This system gives better performance than the other system because if any fault occurs in PV panel then the generator can minimize this problem.

Simulations have been made by considering different sizes of PV, Battery, converter and Diesel generator. The Hybrid result of the figure shows optimal system with total net present cost of \$266,892. However, the diesel only system has a total net present cost of \$379,507 with the cost of energy is \$0.704/kWh which is much higher than hybrid system.

The optimum system contains all the generator hence increases the reliability of the system. It also shows that hybrid system has economic as well as technical advantages over a standalone diesel system. Other advantage of hybrid system having inverter is that it can deliver the required amount of energy directly from PV without discharging the battery as far as enough solar radiation on the site. This increases lifetime of the battery and also prevents the frequent start and stop of diesel generator consequently saves the fuel cost of the system. Thus, PV/Diesel/battery hybrid system is feasible both technically as well as economically.

## References

- [1] District profile of Ilam. (2010). Retrieved from <http://www.ddcilam.gov.np/>.
- [2] HOMER v 2.68. (2010). (National Renewable Energy Laboratory (NREL), USA) Retrieved 2014, from <http://www.nrel.gov/homer>
- [3] Girma, Z. (2013). "Technical and Economic Assessment of Solar PV/diesel Hybrid Power System for Rural School Electrification in Ethiopia". *International Journal of Renewable Energy Research* , 3 (3).
- [4] Bhandari, R. a. (2011). "Electrification using solar photovoltaic systems in Nepal" *Applied Energy*. 88 (2) , 458-465.
- [5] Kamalapur, G. a. (2011). "Rural electrification in India and feasibility of Photovoltaic Solar Home Systems". *International Journal of Electrical Power & amp* , 33 (3), 594-599.
- [6] Daud, A.-K. a. (2012). "Design of isolated hybrid systems minimizing costs and pollutant emissions". 44, 215-224
- [7] Twaha, S. M. (2012). "Applying grid-connected photovoltaic system as alternative source of electricity to supplement hydro power instead of using diesel in Uganda". 37 (1), 185-194
- [8] Tamer Khatib, A. M. (2011). "Optimal Sizing of building integrated hybrid PV/diesel generator system for zero load rejection for Malaysia". *Energy and Building* , 43, 3430-3435
- [9] M.S. Ismail, M. M. "Design of a PV/Diesel stand alone Hybrid System for a community in palestine". *Journal of Asian Scientific Research* , 2, 599-606.
- [10] Benjamin O. Agajelu, O. G. (2013). "Life Cycle Cost Analysis of a Diesel/Photovoltaic Hybrid Power Generating System,". 13 , 19-30.
- [11] Hrayshat, E. S. (2009). techno economic analysis of autonomous Hybrid photovoltaic -diesel battery system. *Journal of energy for sustainable development* , 143-150.
- [12] A. Chaurey, T. K. (2010). Kandpal," techno economic comparison of rural electrocution based on solar home system and PV micro grid ". *Energy policy* , 38, 3118–3129.
- [13] Al-Hadhrami, S. R. (2010). "Study of a solar PVdieselebattery hybrid power system for a remotely located population near Rafha, Saudi Arabia,". *Energy* , 4986-4995.
- [14] Ranaweera, K. I. (2013). "Techno-Economic Optimum Sizing of Hybrid Renewable Energy System- Rural Electrification in Sri lanka. Master Thesis, University of Agder, Department of Engineering Science.
- [15] NASA surface meteorology and solar energy: <http://eosweb.larc.nasa.gov>
- [16] Solar market Research and analysis (online) Available: <http://www.solarbuzz.com/node/3184>
- [17] Nepal Oil Corporation. [http://www.nepaloil.com.np/Selling- Price/13/](http://www.nepaloil.com.np/Selling-Price/13/)